

Sales document

## Wind turbine class K08 delta

Type: N117/3000  
Technical description



K0801\_041798\_EN

Revision 02 / 2014-07-30

- Translation of the original document -  
Document is published in electronic form.  
Signed original at Nordex Energy GmbH, Engineering.

### **Technical modifications**

This document was created with utmost care, taking into account the currently applicable standards.

However, due to continuous development, the figures, functional steps and technical data are subject to change without prior notice.

### **Copyright**

Copyright 2014 by Nordex Energy GmbH.

This document including its presentation and content is the intellectual property of Nordex Energy GmbH.

Any disclosure, duplication or translation of this document or parts thereof in printed, handwritten or electronic form without the explicit approval of Nordex Energy GmbH is explicitly prohibited.

All rights reserved.

### **Contact details**

For questions relating to this documentation please contact:

Nordex Energy GmbH

Langenhorner Chaussee 600

22419 Hamburg

Germany

<http://www.nordex-online.com>

[info@nordex-online.com](mailto:info@nordex-online.com)

# 1. Structure

The wind turbine (WT) Nordex N117/3000 is a speed-variable wind turbine with a rotor diameter of 116.8 m and a rated power of 3000 kW. The wind turbine is designed for 50 Hz or 60 Hz. The wind turbine is designed for class 2a in accordance with IEC 61400-1.

The wind turbine Nordex N117/3000 is made up of the following main components:

- Rotor, consisting of rotor hub, three rotor blades and the pitch system
- Nacelle with drive train, generator and yaw system
- Tubular tower or hybrid tower with foundation or hybrid tower
- Medium-voltage transformer (MV transformer) and medium-voltage switchgear (MV switchgear)

## 1.1 Tower

The Nordex N117/3000 is erected on tubular steel towers or hybrid towers for different rotor hub heights and wind zones.

The tubular steel tower is a cylindrical tower. The top section is conical. Depending on the hub height, the tower consists of four or seven tower sections.

Corrosion protection of the tubular steel tower is ensured by a tower surface coating system according to ISO 12944.

A service lift, the vertical ladder with fall protection system as well as resting and working platforms inside the tower allow for a weather-protected ascent to the nacelle.

The Nordex N117/3000 turbine may also be erected on a hybrid tower. The bottom part of the hybrid tower consists of a concrete tower and the top part of a tubular steel tower with two sections.

The size and the design of the foundation depends on the ground conditions at the intended site. The tubular steel tower is bolted to the anchor cage embedded in the foundation.

A switch cabinet is integrated into the tower base that contains important components of the electronic controls, turbine PC, frequency converter, main switch, fuses and outputs to the transformer and to the generator.

The frequency converter is equipped with a water cooling system. The water heated in the frequency converter is cooled in a water/air heat exchanger. It is located outside above the tower door.

The MV transformer and MV switchgear may be located in a separate transformer substation near the wind turbine. An oil transformer is generally used in this variant with external transformer (TAT).

For the variant transformer inside tower (TIT) the MV transformer and MV switchgear can also be installed in the tower base. In this case, the components in the tower base of the tubular steel tower are arranged on three different levels:

- The MV transformer on the foundation
- The MV switchgear on the first tower platform
- The switch cabinet with frequency converter on the second tower platform

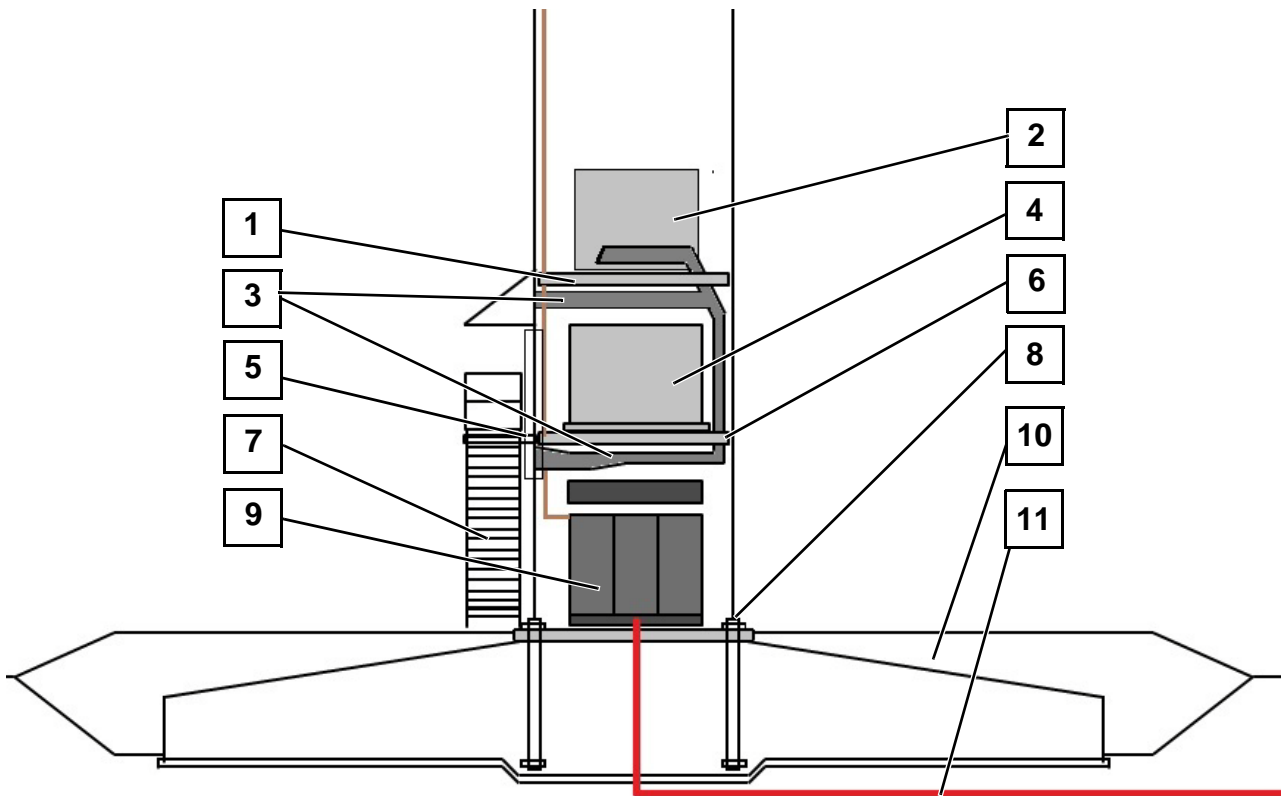

*Fig. 1 Sectional view of the tower base, variant with transformer inside tower (TIT)*

- |    |                          |    |                          |
|----|--------------------------|----|--------------------------|
| 1  | Second tower platform    | 2  | Switch cabinet/converter |
| 3  | Ventilation/cooling      | 4  | MV switchgear            |
| 5  | Tower door               | 6  | First tower platform     |
| 7  | Tower stairs             | 8  | Anchor bolt              |
| 9  | Transformer              | 10 | Soil backfill            |
| 11 | Power cables in conduits |    |                          |

A dry-type transformer is used for the variant transformer inside tower.

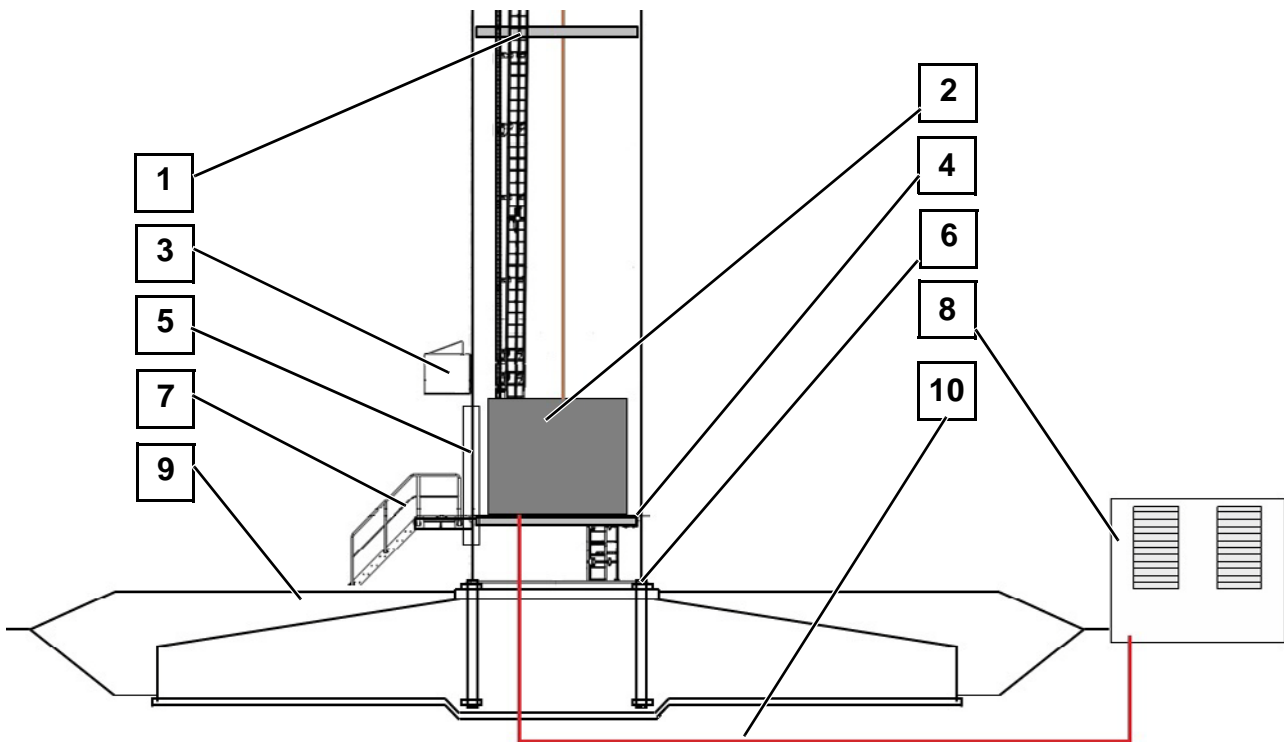

Fig. 2 Sectional view of the tower base, variant with transformer outside tower (TAT)

- |   |                       |    |   |
|---|-----------------------|----|---|
| 1 | Second tower platform | 2  | Switch cabinet/converter                  |
| 3 | Ventilation/cooling   | 4  | First tower platform                      |
| 5 | Tower door            | 6  | Anchor bolt                               |
| 7 | Tower stairs          | 8  | Transformer substation with MV switchgear |
| 9 | Soil backfill         | 10 | Power cables in conduits                  |

All tower base interiors of the hybrid tower are installed on one level.

## 1.2 Rotor

The rotor consists of the rotor hub with three pitch bearings and three pitch drives for blade adjustment as well as three rotor blades.

The **rotor hub** consists of the base element, support structure and spinner. The base element of the rotor hub is made up of a stiff cast structure. Onto this element, pitch bearing and rotor blade are mounted. The rotor hub is covered with the spinner which enables the direct access from the nacelle into the rotor hub.

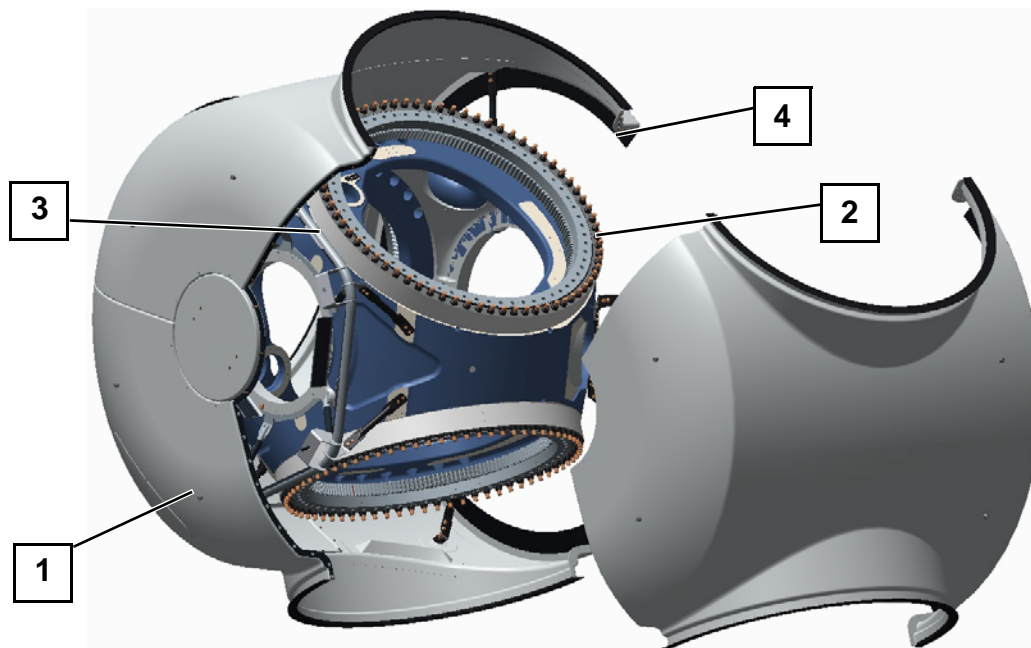

Fig. 3 Hub and spinner of Nordex generation delta WTs

- 1 Spinner segment
- 2 Rotor hub
- 3 Spinner support structure
- 4 Sealings

The **rotor blades** are made of high-quality glass-reinforced and carbon-fiber reinforced plastics. The rotor blade is statically and dynamically tested in accordance with the guidelines IEC 61400-23 and GL IV-1 (2010).

The **pitch system** serves to adjust the pitch angle of the rotor blades set by the control system. For each individual rotor blade the pitch system comprises an electromechanical drive with 3-phase motor, planetary gear and drive pinion, as well as a control unit with frequency converter and emergency power supply. Power supply and signal transfer are realized through a slip ring in the nacelle.

### 1.3 Nacelle

The nacelle contains essential mechanical and electronic components of the wind turbine. The nacelle is mounted on the tower in rotating bearings.

The **rotor shaft** is mounted in the rotor bearing in the nacelle. A mechanical rotor lock is integrated in the rotor bearing, used to securely lock the rotor.

The **gearbox** increases the rotor speed until it reaches the speed required for the generator.

The bearings and gearings are continuously lubricated with oil. A 2-stage pump enables the oil circulation. A combined filter element with integrated coarse and fine filter removes solids. The control system monitors the level of contamination of the filter elements. An additional offline filtration with a super fine filter can be installed as an option.

The gear oil used for lubrication also cools the gearbox. The temperatures of the gearbox bearings and the oil are continuously monitored. If the optimum operating temperature is not yet reached, a thermal bypass directs the gear oil directly back to the gearbox. If the operating temperature of the gear oil is exceeded it is cooled down.

The gearbox cooling is realized with an oil/water cooler that is installed directly at the gearbox. The heated cooling water is cooled together with the cooling water of the generator in a passive cooler on the roof of the nacelle.

The **generator** is a 6-pole doubly-fed induction machine. An air/water heat exchanger is mounted on the generator. The cooling water is recooled together with the cooling water of the gearbox heat exchanger in a passive cooler on the nacelle roof.

The mechanical **rotor brake** supports the aerodynamic braking effect of the rotor blades as soon as the rotor speed falls below a defined value and finally stops the rotor. The aerodynamic braking effect of the rotor is achieved by adjusting the rotor blades perpendicular to the rotation direction. The rotor brake consists of a brake caliper which acts on the brake disk mounted behind the gearbox.

The **yaw drives** optimally rotate the nacelle into the wind. The four yaw drives are located on the machine frame in the nacelle. A yaw drive consists of an electric motor, multi-stage planetary gear, and a drive pinion. The drive pinions mesh with the external teeth of the yaw bearing.

When the nacelle is positioned properly it is locked by means of a hydraulic and an electric brake system. It consists of several brake calipers that are fastened to the machine frame and act on a brake disk. In addition, the electric motors of the yaw drive are equipped with an electrically actuated holding brake.

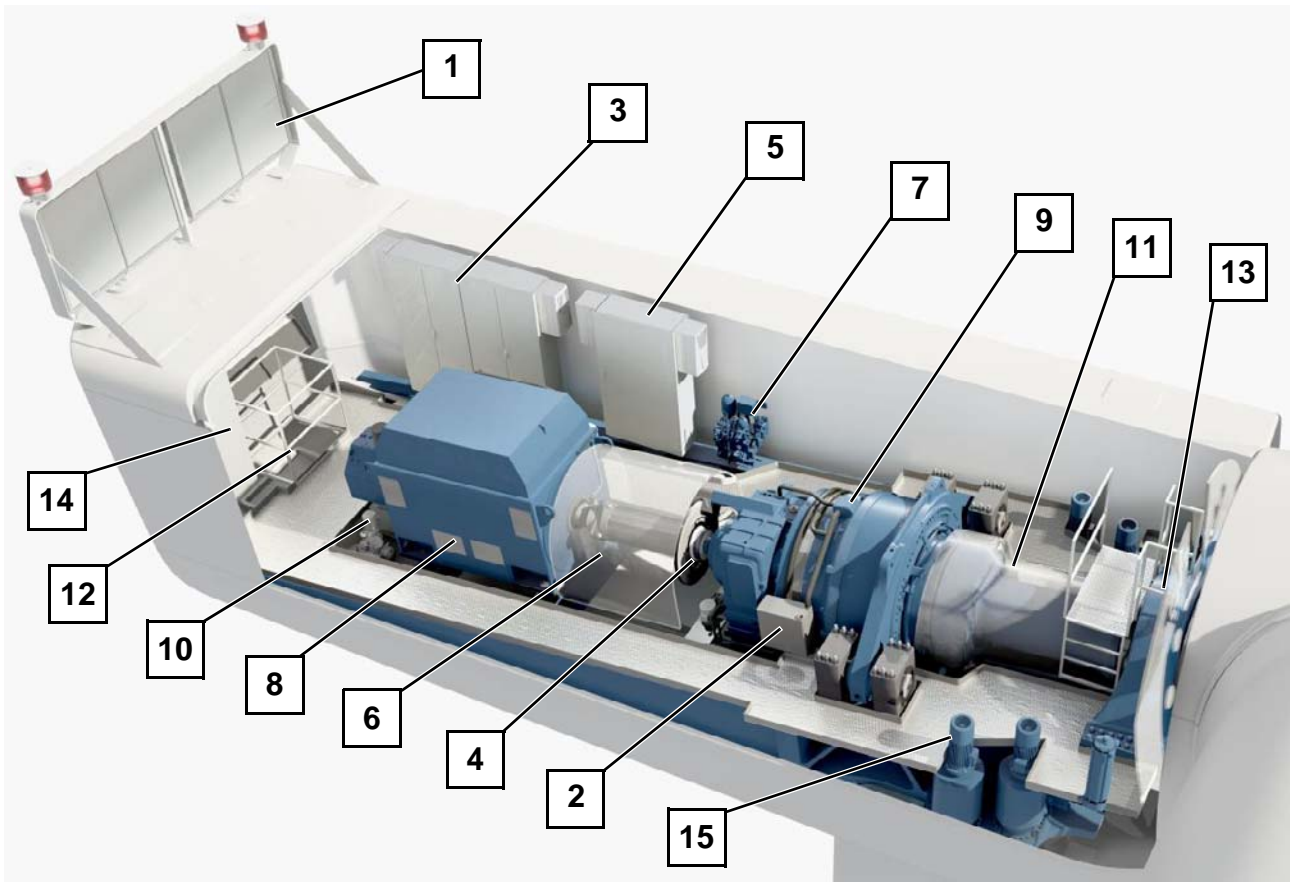

*Fig. 4 Nacelle layout drawing*

- |    |                  |    |                          |
|----|------------------|----|--------------------------|
| 1  | Heat exchanger   | 2  | Gear oil cooler          |
| 3  | Switch cabinet 2 | 4  | Rotor brake              |
| 5  | Switch cabinet 1 | 6  | Coupling                 |
| 7  | Hydraulic unit   | 8  | Generator                |
| 9  | Gearbox          | 10 | Cooling water pump       |
| 11 | Rotor shaft      | 12 | Hatch for on-board crane |
| 13 | Rotor bearing    | 14 | Switch cabinet 3         |
| 15 | Yaw drive        |    |                          |



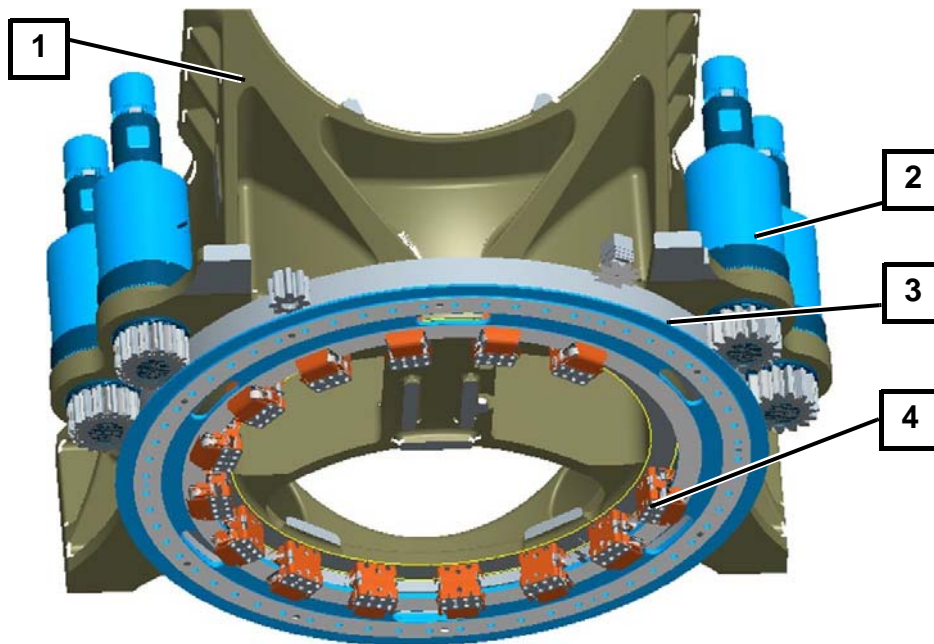

Fig. 5 Components of the yaw system

- 1 Machine frame
- 2 Yaw drives meshing with yaw bearing teeth
- 3 Yaw bearing
- 4 Brake caliper

The **hydraulic unit** provides the oil pressure required for the operation of the rotor brake and the yaw brakes.

## 1.4 Auxiliary systems

The rotor bearing, generator bearing, pitch gearing, pitch races and yaw gearing are each equipped with an **automatic lubrication unit**.

The switch cabinets in the nacelle and in the tower base of the wind turbine are equipped with **air conditioning units**.

Gearbox, generator, hydraulic unit and all switch cabinets are equipped with **heaters**.

An electric **chain hoist** is installed in the nacelle which is used for lifting tools, components and other work materials from the ground into the nacelle. A second, movable **overhead crane** is used for carrying the materials within the nacelle.

Various options of additional equipment are available for the wind turbine.

### Cooling system

Gearbox and generator are cooled by a coupled oil/water circulation. At startup the lightly heated gear oil is directly fed back into the gearbox via a thermal

bypass and only directed into the plate-type heat exchanger after reaching operating temperature.

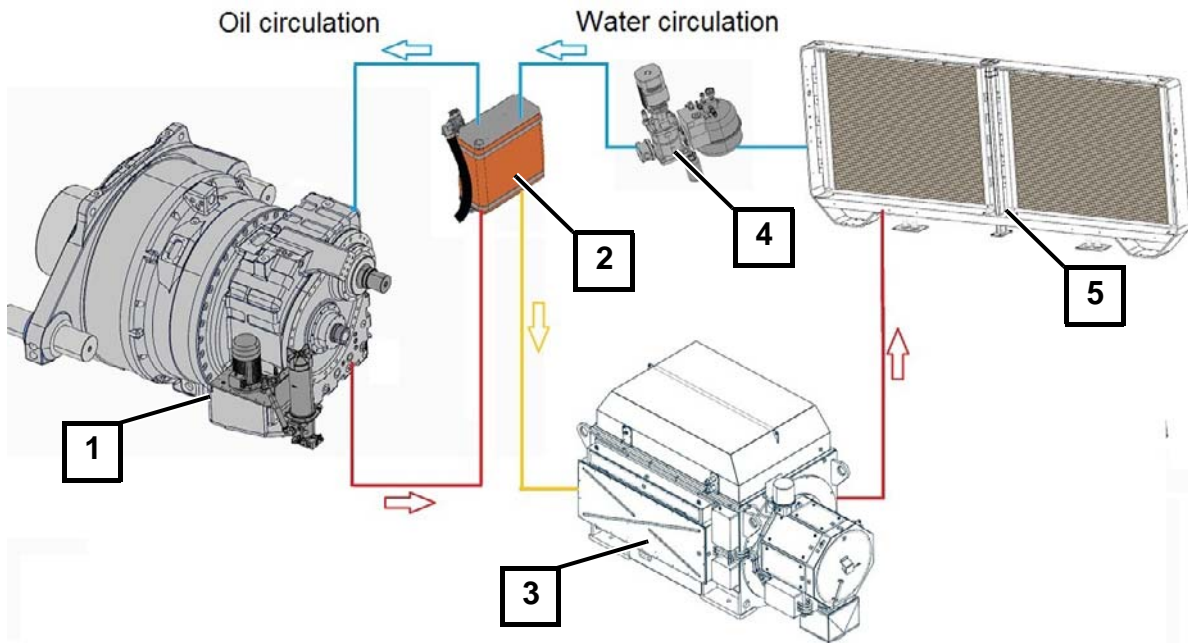

*Fig. 6 Schematic diagram of gearbox cooling and generator cooling*

- 1 Gearbox with oil pump
- 2 Plate-type heat exchanger
- 3 Generator
- 4 Water pump
- 5 Passive cooler

The converter in the tower base is cooled by a water/glycol mixture. A pump conveys the mixture through main converter and heat exchanger. The heat exchanger is equipped with a 2-stage fan that is operated depending on the water temperature.

## 2. Functionality

The turbine operates automatically. A programmable logic controller (PLC) continuously monitors the operating parameters using various sensors, compares the actual values with the corresponding setpoints and issues the required control signals to the WT components. The operating parameters are specified by Nordex and are adapted to the individual location.

When there is no wind the WT remains in idle mode. Only various auxiliary systems are operational or activated as required: e.g., heating, gear lubrication or PLC, which monitors the data from the wind measuring system. All other systems are switched off and do not use any power. The rotor idles.

When the cut-in wind speed is reached, the wind turbine will change to the mode 'Ready for operation'. Now all systems are tested, the nacelle turns into the wind and the rotor blades turn into the wind. When a certain speed is reached, the generator is connected to the grid and the WT produces electricity.

At low wind speeds the WT operates in part-load operation. During this the rotor blades remain fully turned into the wind (pitch angle 0°). The power produced by the WT depends on the wind speed.

When the nominal wind speed is reached, the WT switches over to the nominal load range. If the wind speed continues to increase, the speed control changes the rotor blade angle so that the rotor speed and thus the power output of the WT remain constant.

The yaw system ensures that the nacelle is always optimally aligned to the wind. To this end, two separate wind measuring systems located at the height of the hub measure the wind direction. Only one wind measuring system is used for the control system, while the second system monitors the first and takes over in case the first system fails. If the measured wind direction deviates too greatly from the alignment of the nacelle, the nacelle is yawed into the wind.

The wind energy absorbed from the rotor is converted into electrical energy using a doubly-fed induction machine with slip ring rotor. Its stator is directly connected to the MV transformer, and its rotor via a specially controlled frequency converter. This offers a significant advantage enabling the generator to be operated in a defined speed range near its synchronous speed.

### Safety systems

Nordex wind turbines are equipped with extensive equipment and accessories to provide for personal and turbine safety and ensure stable operation. The entire turbine is designed in accordance with the machinery directive 2006/42/EC and certified as per IEC 61400. For details on the safety devices refer to the current safety manual.

If certain parameters concerning turbine safety are exceeded, the WT will cut out immediately and is put into a safe state. Depending on the cut-out cause, different brake programs are triggered. In case of external causes such as excessive wind speeds or if the operating temperature is too low, the rotor is softly braked by means of rotor blade adjustment.

## Lightning protection

The lightning and overvoltage protection of the wind turbine is based on the EMC-compliant lightning protection zone concept and meets the IEC 61400-24 standard. The lightning protection system meets the requirements of lightning protection class I.

The interdisciplinary EMC and lightning protection concept of the wind turbine is based on a basic concept of EMC and lightning protection zones and the resulting three subconcepts:

- External lightning protection
- Internal lightning protection
- EMC (electromagnetic compatibility)

## Grid type

The 660-V network of the wind turbine is an IT system with insulation monitor. The transformer's neutral point is not grounded.

Using a 660-V/400-V auxiliary transformer, a grid to supply the auxiliary drives, lighting, heating and control unit is created. The 400-V network is available as a TN-S system and is operated with residual-current monitor.

## Auxiliary power of the wind turbine

The power required by the wind turbine in 'stand-by mode' calculates from the individual consumption of the following components:

- Control system (operation control computer and converter)
- Yaw system
- Pitch system
- Hydraulic unit
- Circulation pumps of the cooling systems
- Heaters and fans
- Auxiliary systems (service lift, obstacle lights, options, etc.)

Based on the existing operating experience, a coincidence factor of 0.5 and a power factor ( $\cos \phi$ ) of 0.85 can be assumed. The connection power under consideration of the factors mentioned above is located at a maximum value of 55 kW. The annual energy consumption (power supply from the grid) at locations with average wind speeds amounts to approx. 15000 kWh/year. However, the annual energy consumption highly depends on the location and should be determined specifically. The "anti-icing" option is not included in this consideration.

### 3. Technical data

Climatic design data of the standard version	
Design temperature	Standard -20 °C...+50 °C CCV -40 °C...+50 °C HCV -20 °C...+50 °C
Standard operating temperature range	-20 °C...+40 °C
Operating temperature range CCV	-30 °C...+40 °C
Operating temperature range HCV	-20 °C...+45 °C*
Stop	Standard: -20 °C, restart at -18 °C CCV: -30 °C, restart at -28 °C HCV -20 °C, restart at -18 °C
Max. height above MSL	2000 m**
Certificate	According to IEC 61400-1

\*At ambient temperatures between 40 °C and 45 °C the performance of the WT might be reduced to max. 70 %.

\*\* At installation altitudes above 1000 m, the nominal power can be achieved up to the defined temperature ranges.

Design	
Type	3-blade rotor with horizontal axis Up-wind turbine
Power control	Active single blade adjustment
Nominal power	3000 kW
Nominal power starting at wind speeds of (at air density of 1.225 kg/m <sup>3</sup> )	Approx. 12 m/s
Operating speed range of the rotor	8.0...14.1 rpm
Nominal speed	12.6 rpm
Cut-in wind speed	Approx. 3 m/s
Cut-out wind speed	25 m/s
Cut-back-in wind speed	22 m/s
Calculated service life	20 years

<b>Towers</b>			
Hub height	91 m	120 m	141 m
Designation	R91	R120	PH141
Wind class	DIBt 3/IEC 2a	DIBt 2/IEC 2a	DIBt 2/IEC 3a
Number of tower sections	4	7	2 (+ concrete tower)

<b>Rotor</b>	
Rotor diameter	116.8 m
Swept area	10715 m
Nominal power/area	280 W/m <sup>2</sup>
Rotor shaft inclination angle	5°
Blade cone angle	3.5°

<b>Rotor blade</b>	
Material	Glass-reinforced and carbon-fiber reinforced plastics
Total length	57.3 m
Total weight per blade	Approx. 10.6 t

<b>Rotor shaft/rotor bearing</b>	
Type	Forged hollow shaft
Material	42CrMo4 or 34CrNiMo6
Bearing type	Spherical roller bearing
Lubrication	Continuous and automatic with lubricating grease
Rotor bearing housing material	EN-GJS-400-18U-LT

<b>Mechanical brake</b>	
Type	Actively actuated disk brake
Location	On the high-speed shaft
Disk diameter	920 mm

<b>Mechanical brake</b>	
Number of brake calipers	1
Brake pad material	Sintered metal

<b>Gearbox</b>	
Type	Multi-stage planetary gear + spur gear
Gear ratio	50 Hz: $i = 92 \pm 1 \%$ 60 Hz: $i = 111 \pm 1 \%$
Lubrication	Forced-feed lubrication
Oil type	VG 320
Max. oil temperature	75 °C
Oil change	Change, if required

<b>Electrical system</b>	
Nominal power $P_{nG}$	3000 kW
Nominal voltage	3 x AC 660 V $\pm 10\%$
Nominal current $I_{nG}$ at $S_{nG}$	2916 A
Nominal apparent power $S_{nG}$ at $P_{nG}$	3333 kVA
Power factor at $P_{nG}$	1.00 as default setting 0.9 underexcited (inductive) up to 0.9 overexcited (capacitive) possible
Frequency	50 or 60 Hz

**NOTE**

The nominal power is subject to system-specific tolerances. At nominal power, they are  $\pm 100$  kW. Practice has shown that negative deviations occur rarely and in most cases are  $< 25$  kW. For precisely complying with external power specifications the nominal power of the individual wind turbine can be parameterized accordingly. Alternatively, the wind farm can be parameterized accordingly using the Wind Farm Portal®.

<b>Generator</b>	
Degree of protection	IP 54 (slip ring box IP 23)
Nominal voltage	660 V
Frequency	50 or 60 Hz

<b>Generator</b>	
Speed range	50 Hz: 730... 1315 rpm 60 Hz: 876... 1578 rpm
Poles	6
Weight	approx. 10.6 t

<b>Gearbox cooling and filtration</b>	
Type	1st cooling circuit: Oil circuit with oil/water heat exchanger and thermal bypass 2nd cooling circuit: Water/air together with generator cooling
Filter	Coarse filter 50 µm Fine filter 10 µm
Flow rate	Stage 1: Approx. 75 l/min Stage 2: Approx. 150 l/min
Offline filter (optional)	5 µm

<b>Generator cooling</b>	
Type	Water circuit with water/air heat exchanger
Flow rate	Approx. 160 l/min
Coolant	Water/glycol-based coolant

<b>Converter cooling</b>	
Type	Water circuit with water/air heat exchanger and thermal bypass
Coolant	Water/glycol-based coolant

<b>Pitch system</b>	
Pitch bearing	Double-row four-point contact bearing
Lubrication of gearing and race	Automatic lubrication unit with grease
Drive system	3-phase motor incl. spring-actuated brake and multi-stage planetary gear
Emergency power supply	VRLA batteries

<b>Hydraulic system</b>	
Hydraulic oil	VG 32



<b>Hydraulic system</b>	
Oil quantity	Approx. 25 L
Thermal protection	Integrated PT100

<b>Yaw drive</b>	
Motor	Asynchronous motor
Gearbox	4-stage planetary gear
Number of drives	4
Lubrication	Oil, ISO VG 150
Yaw speed	Approx. 0.5 °/s

<b>Yaw brake</b>	
1st type	Disk brake with hydraulic brake calipers
Brake pad material	Organic
Number of brake calipers	14
2nd type	Electric spring-actuated brake on every driving motor

Nordex Energy GmbH  
Langenhorner Chaussee 600  
22419 Hamburg  
Germany  
<http://www.nordex-online.com>  
[info@nordex-online.com](mailto:info@nordex-online.com)